



# Haisen Universal Smart Remote Control



## Electric Parameters

Working Voltage:	AAA battery * 2pcs (2.2-3V)
Screen OFF Duration:	60 seconds
Icon Flicking Duration:	5 seconds
S (start) button ON Duration:	10 seconds
M(Memory) button Flicking Duration:	3 seconds
Carrier Frequency:	38KHz±2KHz
Operation Distance Max.:	15M/4 ft (3V)
Emission Angle:	<30°
Standby Current:	<1.2uA
tWorking Current:	<5mA
Peak Current:	<30mA
Working Temp:	-20°C to 60°C
Storage Temp:	-30°C to 85°C

## Dimensions

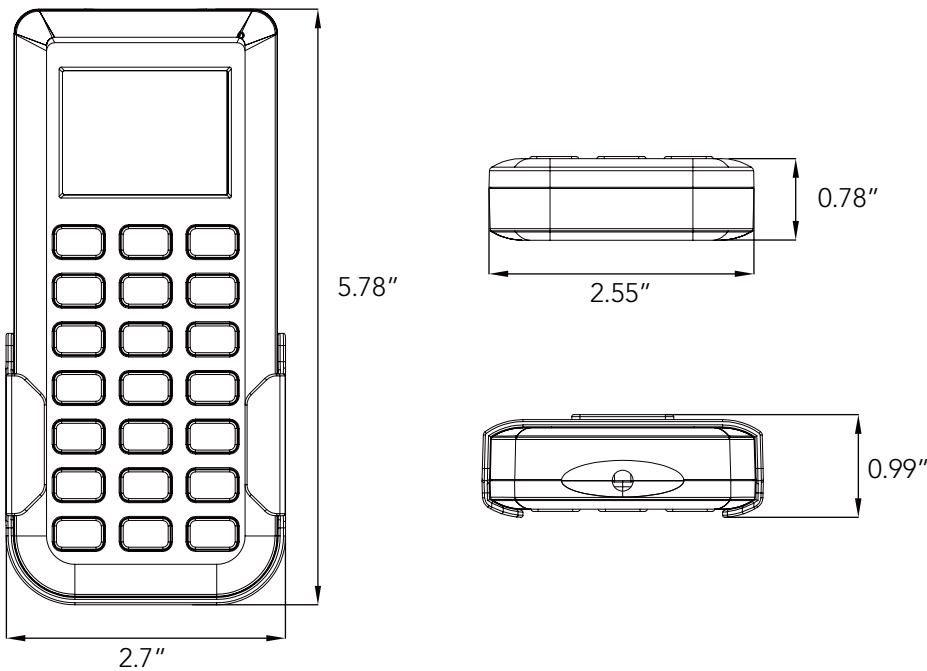



## LCD Screen Display

	Brightness Output		Detection Area
	CCT Output		Holdtime
<b>AM</b>	Auto Mode (ON if it's shown as AM)	<b>DH<sup>ON</sup><sub>OFF</sub></b>	Daylight Harvesting (ON/OFF)
<b>SC-01</b>	Scene Options (1-4)		Standby Dim Level
<b>S M</b>	S(Start) M(Memory)		Standby Period
			Daylight Threshold

## Button Layout

Button	Description	Button	Description	Button	Description
	1.Turn on or off light 2.Exit sensor mode and enter into ON/OFF mode.		Press this button, enter into sensor mode and perform the last parameter, press this button and Auto Mode will show on LCD screen display, means commands received successfully.		Press the button to enter into factory settings, means sensor starts to detect motion and turn on light automatically and only keep 5S holdtime then turn off the light.
	Press the button to choose in 4 optional scenes; parameters can be saved into each scene and directly activate it.		Press the button to start programming; the S icon will appear on the LCD screen, and disappear if no action within 10S, need to press it again.		Press the button to save the parameters, the M icon will appear on the LCD screen, means parameters saved successfully.
	Press the button to deliver the saved parameters to target sensors.	*	Press the button to relatively adjust sensitivity from the sensor according to real installation height, make sensors working more perfectly in the environment.	*	Press the button to deliver the last parameters, instead of "START-MEMORY-APPLY"
	Press the button, the icon will flick on LCD screen display, then use +/- buttons to choose the wanted parameters.		Press the button, the icon will flick on LCD screen display, then use +/- buttons to choose the wanted daylight level; the max level is 400lux, --- means disable, LEN means learning ambient brightness.		Press the button, the icon will flick on LCD screen display, then use +/- buttons to choose the wanted standby dim level.
	Press the button, the icon will flick on LCD screen display, then use +/- buttons to choose the wanted holdtime.		Press the button, numbers on LCD screen display gets higher till the wanted one appears.		Press the button, the icon will flick on LCD screen display, then use +/- buttons to choose the wanted standby period; the min is 0S, the max is infinite.
*	(Only supporting sensors with CCT tunable feature) Press the button, then icon will flick on LCD screen display, then use +/- buttons to choose from the saved CCT options(2700K, 3500K, 4000K, 5000K, 5700K, 6500K).		Press the button, numbers on LCD screen display gets lower till the wanted one appears.		Press the button, the icon will flick on LCD screen display, then use +/- buttons to choose wanted brightness level. *In ON/OFF mode, output dimming range is 10%-100%; In SENSOR mode, output dimming range is 60%-100%.
	This is a reserved button for future updates with unexpected features	*	Make parameters according to daylight harvesting conditions, then press this button to activate this function; DH-ON will show on LCD screen display.		Press the button to quickly perform testing function, keep only 2S ON then OFF, till motion gets detected and turn on light again.

\* only works with newer generation sensors, please check with manufacturer



## Operation Guide

1. How to quickly set multiple sensors to perform the same parameters?

### Solution A:

**At the first sensor** - press AUTO to enter the SENSOR mode, press START to set parameters (detection area, holdtime, daylight threshold, standby dimming level and standby period), press MEMORY to save parameters, and press APPLY to send parameters. You will see light OFF then ON for once as command's received.

**At the other sensors** - press AUTO to enter the SENSOR mode and press APPLY to send parameters. You will see light OFF-ON for once as command's received.

### Solution B:

Use the SCENE function if you have preset parameters - Press AUTO to enter the SENSOR mode, choose from the scene options (1, 2, 3, 4), and press SEND. You will see light OFF-ON for once as command's received.

2. In SENSOR mode, how to turn off the sensor function(disable sensor function)?-

**When the light is ON:** press ON/OFF to turn OFF the light, and press ON/OFF again to turn on the light, don't press any other buttons.

**When the light is OFF:** press ON/OFF to turn on the light, don't press any other buttons.

3. How to perform SENSOR mode when sensors are already in ON/OFF mode?

### Solution A:

Press AUTO to enter the SENSOR mode and perform the last parameter setting. The corresponding parameters will be displayed on the LCD screen.

### Solution B:

Press RESET to enter the SENSOR mode and perform factory setting parameters. The corresponding parameters will be displayed on the LCD screen.

4. How to enter and exit TEST mode?

**Enter:** In any mode, after pressing TEST button, the sensor enters the TEST mode, means keeping the light ON for 2S, turns off the light, lights ON again after detecting motion and keeps 2S then OFF; keep running this way.

**Exit:** Press the ON/OFF button to turn off the light and exit the TEST mode directly;

Or press the RESET button to exit the TEST mode, enter the SENSOR mode and performing factory Settings;

Or press the AUTO button to exit the TEST mode, enter the SENSOR mode and performing the last parameter settings.



<b>Project Name</b>	
<b>Catalog #</b>	
<b>Job Type</b>	
<b>Prepared By</b>	
<b>Notes</b>	

## Ordering Information

<b>Part #</b>	<b>Description</b>
HD06R	HAISEN Universal Smart Remote Control