



Bi-Level Microwave Sensor for High Bay Light



Description

The Highbay ANT-5-4T is a microwave sensor. This slim, low-profile sensor is designed for installation inside the bottom of a light fixture body.

Specifications

Power Supply:	12-24V DC, .50mA
Dim Control Output:	0-10V, max. 25mA sinking current
HF System:	5.8GHz \pm 75MHz
Transmission Power:	<0.2mW
Detection Radius:	20% / 50% / 75% / 100% (1-8m)
Mounting Height:	Max 50ft.
Time setting:	10s / 1min / 5min / 10min / 15 min / 20min / 30min / 60min
Light-control:	24H / 10LUX / 30LUX / 50LUX
Temperature:	-20°C~60°C
IP Rating:	IP65

Warning

Note: Warm up time is 15 seconds after the sensor connects input power initially, the light will power on for 15 seconds, then go to dimming to work normally.

Note: Factory Default Setting: 100% sensitivity, Hold on Time: 5 min, Daylight sensor is \otimes , Dimming level: 30%, Dimming time: 60 minutes.

Note: Any time settings are changed by remote control, the LED light will flash on/off to confirm.

Dimensions

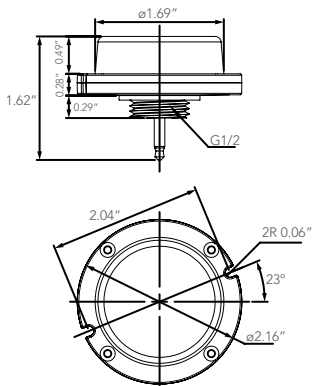



Corridor Function

3 levels of the light control: 100%--dimming light (0%, 10%, 30%, 50%) --off, 2 selectable delayed wait time: motion hold stand-by time, Selectable daylight threshold

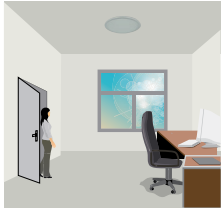

With sufficient natural light, the light does not switch on when presence is detected

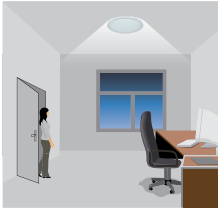

With insufficient natural light, the sensor switches on the light automatically when presence is detected

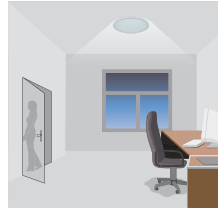

After hold-time, the light dims to stand-by level if the surrounding natural light is below the daylight threshold.



Light switches off automatically after the stand-by period elapses

Daylight Sensor Function

Open the smart photocell sensor by pushing when the remote control is in setting mode.



The light switches on at 100% when there is movement detected.

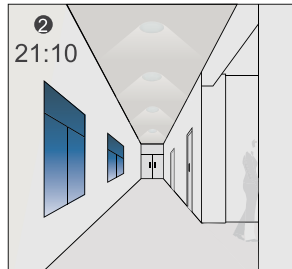

The light dims to stand-by levels after the hold time.



The light remains in dimming level at night.

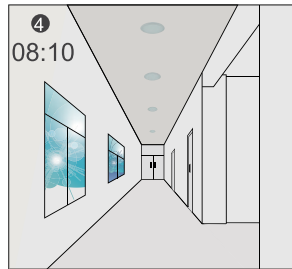
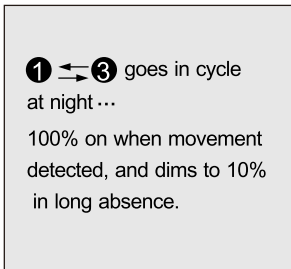

When natural light levels exceed setpoint off to light, the light will turn off even if the space is occupied.

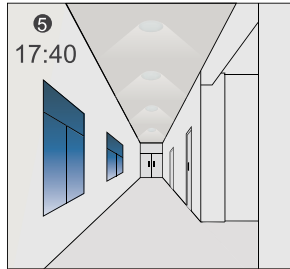

The light automatically turns on at 10% when natural light is insufficient (no motion)

Settings on this demonstration:

Hold-time: 30mins

Setpoint On: 50lux

Setpoint Off: 300lux

Stand-by Dim: 10%

Stand-by period: +∞

(When the smart photocell sensor open, the stand-by time is only +∞)

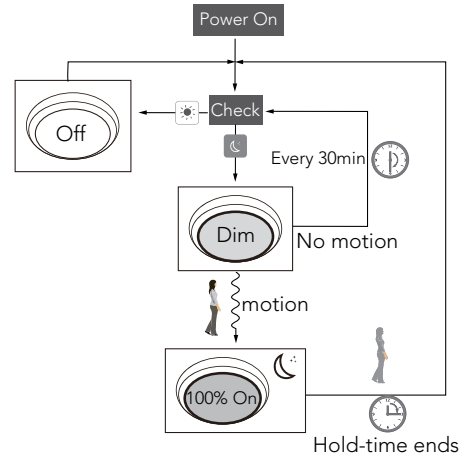

Sensor Coverage

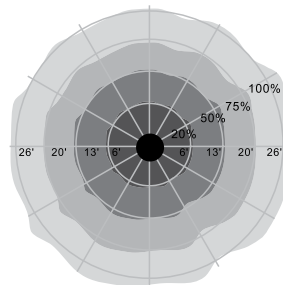
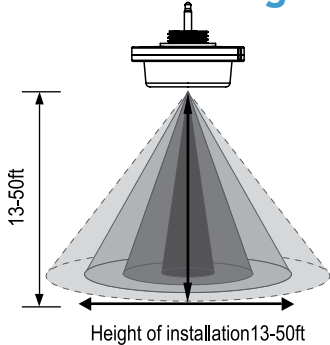

Daylight Harvesting Function setting by Remote Control in Manual of RC-100



Project Name	
Catalog #	
Job Type	
Prepared By	
Notes	

Ordering Information

Part #	Description
ANT-5-4T	Sharkward 12-24V DC 0-10V Plug And Play Microwave Sensor