



Description

Edgelit Aluminum Exit Sign

Illumination:

- Ultra bright, energy efficient, long life Red or Green LEDs.
- UV-stabilized ultra-clear acrylic edgelit panel provides consistent, uniform illumination.
- Double face utilizes factory installed silver or white mylar background panel

Electrical:

- Dual 120/277 voltage.
- Charge rate/power "ON" LED indicator light and push-to-test switch for mandated code compliance testing.
- 4.8V long life, maintenance-free, rechargeable NiCd battery (EM models only).
- Internal solid-state transfer switch automatically connects the internal battery to LED board for minimum 90-minute emergency illumination.
- Fully automatic solid-state, two rate charger initiates battery charging to recharge a discharged battery in 24 hours.

Mounting:

- Aluminum mounting canopy included for top, end or back mount.

Housing:

- Premium-grade, die-cast aluminum housing (also available in optional black or white powder-coated finishes).
- Self-adhesive Chevron appliques and guide template provided for directional indication.

Options:

- 2C-120V/2C-277V: Voltage-specific dual circuit option on the AC-only unit enables it to be connected to two different supplies at the same time.
- SDT: Self-diagnostic feature performs monthly, biannual, and annual tests to ensure reliable operation and meets electrical and life safety codes.
- USA: Substantial transformation assembly in the U.S. complies with "Assembled in the USA" under the Buy American Act.
- SPV: UL Listed for 208/220/240 Volt, 50/60Hz.
- Custom: Signs available with requested 'special' wording.

Warranty/Listing:

- Seven year warranty on all electronics and housing. Battery prorated for five years.
- Meets UL924, NFPA 101 Life Safety Code, NEC, OSHA, Local and State Codes.
- UL Listed for damp locations (0°C – 50°C).
- Certified to CEC under Title 20 Regulations.



Dimensions:

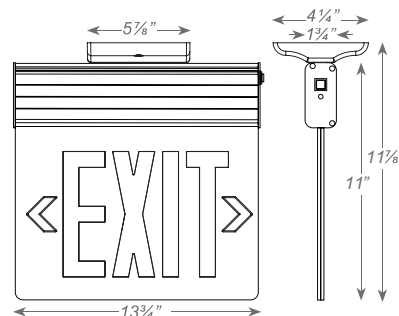



Project Name	
Catalog #	
Job Type	
Prepared By	
Notes	

Fixture Ordering Information

Model	No. of Faces		Letter Color		Panel		Housing Color		Battery		Options		
LL-ELXTEU	1	Single Face	R	Red	C	Clear ¹	W	White	(blank)	AC-Only	2C-120	Dual Circuit With 120V Input ²	
	2	Double Face	G	Green	M	Mirror	B	Black	EM	Battery Backup	2C-277	Dual Circuit With 277V Input ²	
					W	White	A	Aluminum				SDT USA SPV CUSTOM	Self-Diagnostics ³ Assembled In USA 208/220/240 Volt, 50/60Hz ⁴ Custom Wording

¹ With single face only.

² Not available with SDT.

³ Available only with AC units.

⁴ Available only with EM units .