



Emergency Power Systems



Description

Midsized-electrical inverter systems for powering up to 375 to 600 watts of incandescent, fluorescent, induction or LED lighting loads. Pulse width modulated (PWM) output design provides clean, 60 Hz. sinusoidal emergency power to loads

- All models are designed for fast, easy wall mounting

Electrical Specifications:

Input

- Input Voltages: Universal 120 or 277VAC, 60Hz (User selectable with two jumper wires provided)
- Input Frequencies: 60Hz \pm 2%
- Input Surge Protection: Meets UL924
- Input Protection: Provided by Service Panel rated at 20 amps maximum

Output

- Output Voltages: 120 or 277VAC, 60Hz
- Efficiency Rating: 98% at full rated load (line)
- Waveform: Sinusoidal (digitally controlled)
- Static Voltage: \pm 5% during battery discharge. 0-100% linear load.
- Output Frequencies: 60Hz. \pm 0.3Hz during emergency cycle
- Output Distortion: Less than 3% THO (linear load)
- Transfer Time: Less than 1.0 second
- Load Power Factor Range: 0.88 Lead to 0.88 Lag
- Minimum Loading: 0% of rated system capacity
- Output Protection: Circuit breaker and overload shut down protection

Mounting

Surface mount models are designed for mounting to walls by means of keyhole slots provided in the back of the unit housing

Housing

- Heavy duty steel cabinet is finished in white baked-on powder paint providing scratch and corrosion resistance
- Optional special color paint (-SP) finishes are available upon request

Warranty/Listing:

- **Unit:** (excluding lamps) Full coverage against defects in materials and workmanship for 3 years from date of shipment
- **Battery:** 3 years Lead-Acid, 5 yrs NiCd full warranty plus an additional 7 years of pro-rata coverage
- All models are UL924 Listed and meet NFPA 101 LifeSafety Code, NEC, OSHA, Local and State Codes.
- UL Listed for damp locations (20° - 30°C)
- Certified to CEC Under Title 20 regulations



Dimensions:

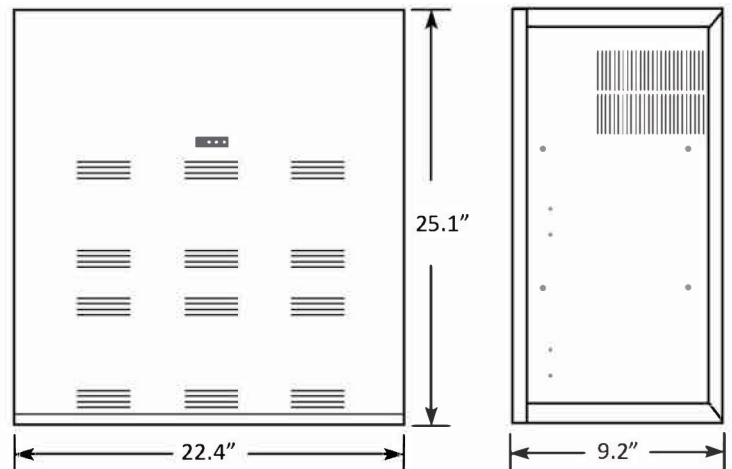



The LL-LPS Series is designed to provide 375 to 600 watts of emergency power to incandescent, Fluorescent, Induction and/or LED fixtures. The LL-LPS unit provides clean, sinusoidal AC output power allowing it to be remotely mounted up to 1,000 feet away from the controlled fixture(s).

Unlike a ballast fluorescent emergency pack, the LL-LPS provided power to the input side of the fixture (including the fixture ballast) eliminating any chance of incompatibility. The LL-LPS Series is designed for surface mounting. All LPS systems will provided emergency power output for a minimum of 90 minutes.

Features

- For powering incandescent, fluorescent, induction and LED fixtures *
- Sinusoidal output eliminates compatibility problems
- Universal 120/277VAC, 60Hz. input/output
- Unit capacities up to 600 watts
- "Soft Start" design reduces fixture inrush current
- Unit may be installed up to 1,000 feet from controlled fixture(s)
- Lumen output from fixture is 100% of nominal
- Unique design eliminates compatibility problems with LED drivers as well as fluorescent and induction ballasts
- Compatible with dimming ballasts
- Normally-ON and/or Normally-OFF load output
- Provisions for local switching capability - Always on during emergency conditions regardless of local switch position
- Emergency fixtures can be ON, OFF or SWITCHED
- So/id-state, line latched low voltage disconnect provides protection against battery deep discharge
- Long life, maintenance-free lead-calcium battery
- Momentary test switch
- AC-ON, Charge-ON and Inverter-ON LED indicators

* Consult factory for compatibility for other lamp types

Wiring

Connection to an unswitched AC circuit is required by the NEC. Wiring access is provided for by conduit knockouts in the unit housing

Load Compatibility

LL-LPS model's clean, sinusoidal AC output will operate incandescent lamps as well as all common fluorescent, induction and LED lamp types. Consult factory for compatibility with all other lamp types. Lighting loads are driven at 100% output for the entire emergency power cycle. This outstanding feature translates into greater occupant egress vision and safety.

System Options⁽¹⁾⁽²⁾

Add Suffix	Description
-OCB1	One Output Breaker
-OCB2	Two Output Breakers
-ICB	Input Breaker
-SP	Special Housing Color (specify)
-4AO	Adjustable Output/Dimmer Bypass ⁽³⁾⁽⁴⁾
-4C	Four Output Circuit Switching ⁽³⁾⁽⁴⁾
-SDT	Self-Testing / Self-Diagnostics ⁽³⁾

⁽¹⁾ Other options available. Consult factory.

⁽²⁾ Some options may impact product UL listing. Consult factory.

⁽³⁾ For more information, separate specification sheets are available on the -4AO, -4C and -SDT options. Consult factor

⁽⁴⁾ Not available together

General Specifications:

Model Number	INPUT / OUTPUT VOLTS	90 min. CAPACITY (Watts/VA)	SYSTEM WEIGHT		SYSTEM EFFICIENCY (FULL LOAD)	NUMBER OF BATTERIES	BATTERY VOLTAGE (VDC)	BATTERY CURRENT (AMPS)	AC INPUT CURRENT (MAX AMPS)		THERMAL OUTPUT in BTUs	
			Lbs.	Kg.					120VAC	277VAC	On-Line	Emergency
LL-LPS-375	120/277	375/375	113	51.3	98%	5	60	7.3	3.43	1.49	11	205
LL-LPS-600	120/277	600/600	172	78.1	98%	8	96	7.1	5.50	2.38	15	275



Batteries And Charger

Battery

Battery: Sealed Lead Calcium (10 year life)

Battery Voltage: 60VDC for LL-LPS-375, 96VDC for LL-LPS-600

Runtime: 90-minutes standard - based on battery performance at 77°F (25°C). Other runtimes available, consult factory.

Battery Protection: Low Voltage Battery Disconnect protects the battery from being severely damaged by deep discharge during prolonged power failures. DC Overload and Short Circuit Protection provided by a DC input fuse.

Charger

Charger Type: Fully automatic, temperature compensated, dual-mode charger

Power Consumption (Charger Only):

37W max. (2.5W in standby) for LL-LPS-375 model

56W max. (5W in standby) for LL-LPS-600 model

Recharge Duty Cycle: Meets UL924 requirements

Battery Circuit Breaker: Also used as a battery isolator

Controls: Momentary test switch, AC-ON, Charge-ON and Inverter-ON LED indicator lights

Safety Circuitry: AC Lockout prevents battery discharge prior to initial unit power-up.

Brownout Protection automatically switches the unit to emergency mode when utility voltage is significantly reduced.

Environmental

High Altitude operation: Maximum operating temperature drops 1°C per 300 meters (2°F per 1000 feet) above sea level

Operating Temperature Range: 20°C to 30°C

NOTE: Optimum system performance between 20°C and 30°C; temperatures outside of this range will affect battery performance and life.

Relative Humidity: 95% non-condensing

Operation

Upon failure of the normal utility power the LL-LPS unit is automatically turned on by a solid-state switching circuit and provides a minimum of 90-minutes of emergency power to the connected load. Lumen output will be maintained at 100% of the lamp's rating throughout the entire duration.

A solid-state low voltage disconnect circuit is used to protect the battery from being severely damaged by a deep discharge.

When normal utility power is restored, the unit switches the load back to normal utility operation and the fully automatic, temperature compensated, dual mode charger begins to restore the battery; bringing it to full charge within UL924 specified parameters.

System Status Monitoring Panel

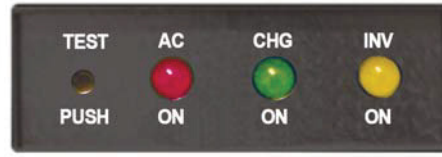

All LL-LPS systems provide a monitoring panel on the front of the unit to show operating status at all times. The panel provides a test switch for user initiated system tests and a 3-LED array that provides an intuitive visual indication of unit readiness.

Load Compatibility

The LL-LPS system's sinusoidal AC output design eliminates voltage drop and proximity concerns. This allows added flexibility in installation location as LL-LPS units can be installed hundreds of feet from the units they power. This means LL-LPS units to be located conveniently out of sight in closets or utility rooms without interrupting architectural aesthetics.

In lighting applications, no special or additional emergency fixtures are necessary. Simply designate and connect existing lighting fixtures, either interior or exterior, to the LL-LPS unit for emergency operation eliminating the need for exposed, stand-alone emergency luminaires.

LL-LPS System Advantages

Compared to traditional discrete emergency lighting units, the LL-LPS Series provides emergency illumination from a single power source resulting in lower maintenance overhead and routine testing expenses. LL-LPS units lower installation costs by powering existing lighting fixtures during emergencies. And because connected fixtures are driven at full brilliancy, they provide far superior egress lighting and deliver improved occupant safety.



Suggested Specifications

An inverter system with sinusoidal output shall be supplied capable of powering any combination of lighting fixtures, including incandescent, fluorescent, induction and/or LED light sources without compatibility problems.

The system shall transfer in less than 1.0 second to reliably back up lighting fixtures without loss of illumination and operate any and all connected lighting fixtures at full lumen output during the complete 90-minute discharge cycle.

The input voltage shall be the same as the output voltage and shall be single phase 120/277 volts, 60Hz. Output capacity will be (375W/375VA) or (600W/600VA) for a minimum duration of 90-minutes.

The design shall be a standby, off-line inverter with on-line efficiency of 98%; on-line double conversion UPS systems shall not be considered acceptable alternatives. LL-LPS system output shall be a PWM generated sine wave with less than 3% total harmonic distortion with "Soft-Start" design reducing fixture inrush current. The system shall also provide short circuit and overload protection as standard.

An intuitive three LED display shall provide system operational information at a glance and alert user to any malfunction in system performance. Authorized maintenance personnel shall have access to the system's controls while being protected from any live exposed connections.

Protective devices shall include AC line fuses, DC input breaker and a DC input fuse. The entire LL-LPS system, including batteries, shall be provided in compact cabinetry which shall have provisions for surface mounting.

System shall be capable of providing up to 4 switch bypass circuits, adjustable output with 2.5 to 10 volt dimmer bypass and self-test/self-diagnostics, were necessary

System shall utilize a sealed lead calcium battery with a 10 year design life. The charger shall be temperature compensated, dual mode type, and recharge the batteries as per UL924 guidelines. Entire system shall be tested, approved, and labeled to UL924 Emergency Lighting and Power Systems standards.

Wiring Diagram

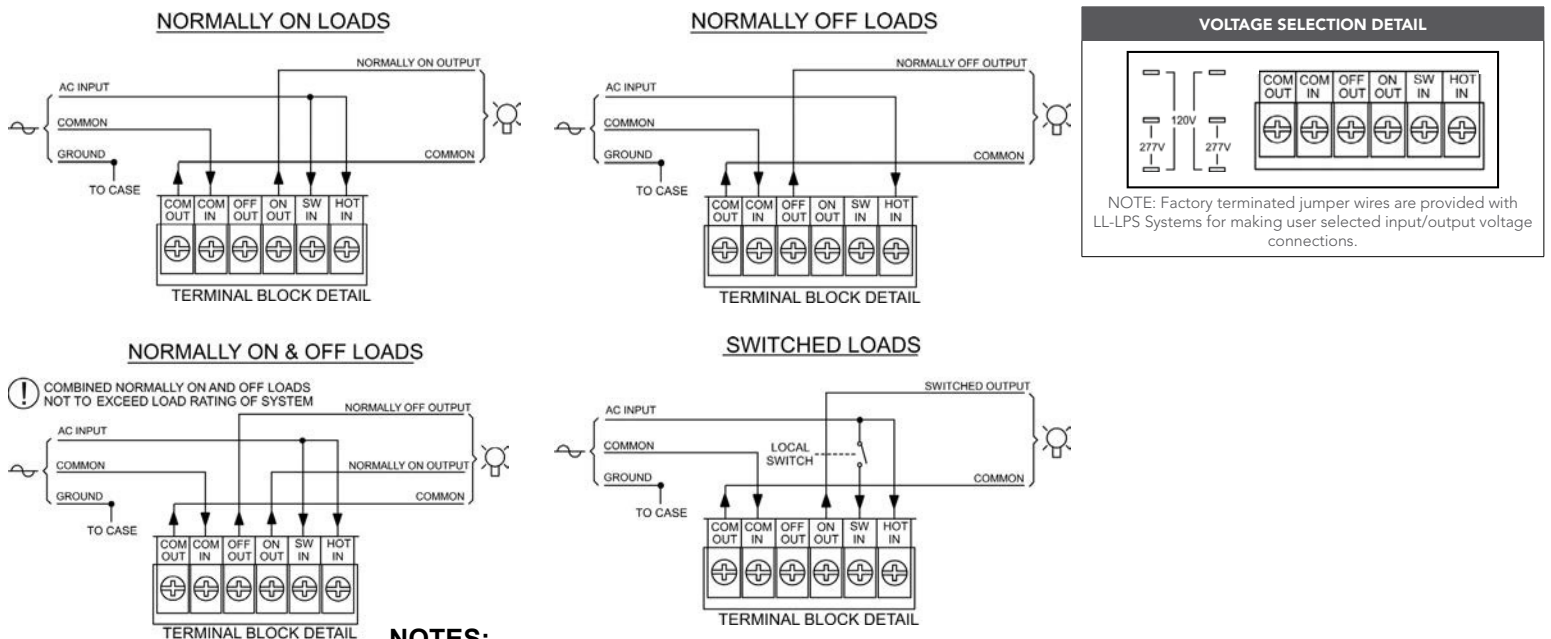

VOLTAGE SELECTION DETAIL

NOTE: Factory terminated jumper wires are provided with LL-LPS Systems for making user selected input/output voltage connections.

- NOTES:**
- ⚡ INPUT SUPPLY FROM UNSWITCHED UTILITY RATED 20 AMPS MAXIMUM.
 - 💡 OUTPUT(S) TO LIGHTING LOADS