



Description

Semi-Recessed MR-16 Emergency Unit

Illumination:

- Two fully adjustable ultra bright, round, 7.0 watt, MR-16 halogen lamp heads standard.
- High performance MR16 halogen lamps with smooth metallized reflector and glass lens for optimal light distribution.

Electrical:

- Dual 120/277 voltage.
- Charge rate/power "ON" LED indicator light and push-to-test switch for mandated code compliance testing.
- LVD (low voltage disconnect) prevents battery from deep discharge.
- 6V maintenance-free, rechargeable sealed lead acid battery.
- Internal solid-state transfer switch automatically connects the internal battery to lamp heads for minimum 90-minute emergency illumination.
- Fully automatic solid-state, two rate charger initiates battery charging to recharge a discharged battery in 24 hours.

Mounting:

- Universal knockout pattern on the backplate for wall mount. Snaps into place making internal electrical connections.
- Knockout for conduit applications.

Housing:

- Injection-molded, engineering grade, 5VA flame retardant, high-impact resistant, thermoplastic in white or black finish.

Options:

- USA: Substantial transformation assembly in the U.S. complies with "Assembled in the USA" under the Buy American Act.
- LED: 3.6W high performance MR-16 base LED Lamps for increased center-to-center spacing.
- PLED: 5.0W high performance MR-16 base LED Lamps for premium center-to-center spacing.

Warranty/Listing:

- Seven year warranty on all electronics and housing. Battery prorated for two years.
- Meets UL924, NFPA 101 Life Safety Code, NEC, OSHA, Local and State Codes.
- UL Listed for damp locations (20°C – 40°C).



Dimensions:

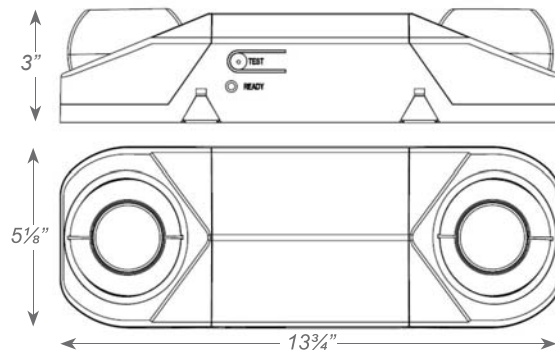



Project Name	
Catalog #	
Job Type	
Prepared By	
Notes	

Fixture Ordering Information

Model	Housing Color		Options	
LL-RMR-16	Blank B	White Black	LED USA PLED	3.6W High Lumen White LED Lamps Assembled in USA 5.0W High Lumen White LED Lamps