



## Description

The LITELUME™ Round Highbay Emergency Battery Backup With Remote Control 277-480V series LED emergency drivers are designed for use with UFO LED high fixtures with 0-10V dimmable LED drivers, it allows the LED UFO high bay to be used for both normal and emergency operation.

## Features

- Simple wiring: directly connect to AC INPUT of LED driver.
- Constant power output 30W/40W/60W.
- Universal input range, 277-480Vac, 50/60Hz.
- High output voltage DC 400V .
- Optimized design for UFO highbay fixture, private mold patent design.
- Built-in integrated junction box.
- Protection: over-voltage, short-circuit, over-load, open-circuit.
- Wireless remote control or non-remote control for emergency test are optional.
- UL Listed for field or factory installation.
- Comply with UL924 standard and CSA 22.2, No. 141 for USA and Canada.

## Dimensions

Driver: 5.75" x 10.78"  
Remote: 5.11" x 0.63"

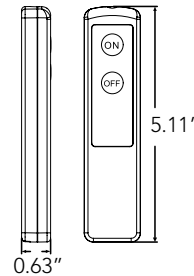
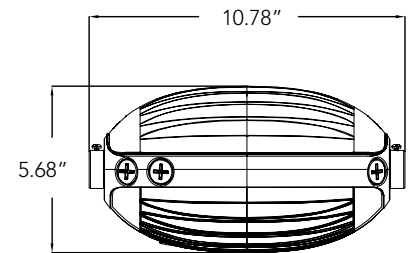
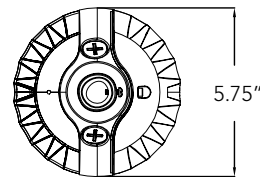

## Specifications

Input Voltage:	277-480VAC 50/60Hz
Charging Time	≥24Hours
Input Current	100mA max
Input Power	20W max
Emergency Time	90minutes
Ambient Temperature	5°C to 50°C
Test switch/charging indicator light	Remote control, Non-remote control
Battery:	Li-ion battery
Output Voltage:	400V DC
Output Power:	30W/40W/60W
Warranty:	7 years



# Wiring Diagram

## With Dimming

For UFO LED Highbay <300W with 0-10V dimming function

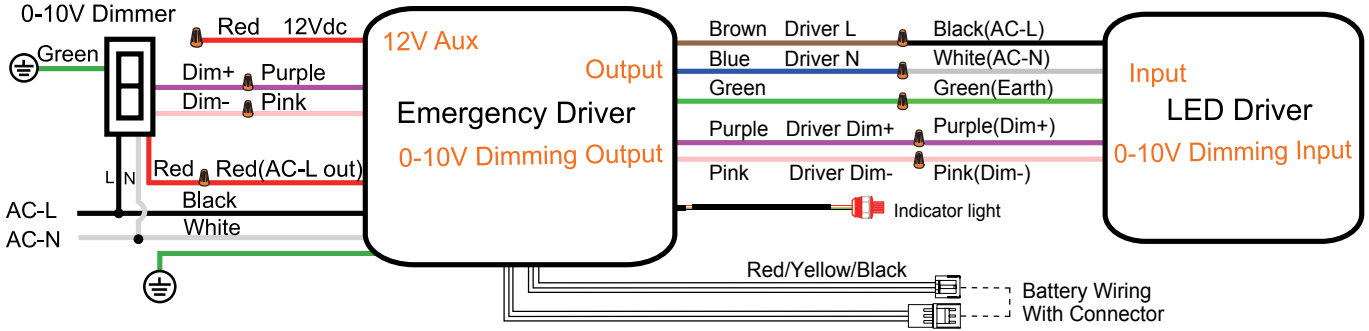

### IMPORTANT

Emergency driver 0-10V dimming wires must be connected to UFO LED driver dimming wires for EM to function properly. Will NOT operate if not connected.

### RECOMMENDATION

Emergency output power  $\geq 20\%$  output power of UFO LED Highbay

## With Wall Switch(Without Dimmer)

For UFO LED Highbay <300W with 0-10V dimming function

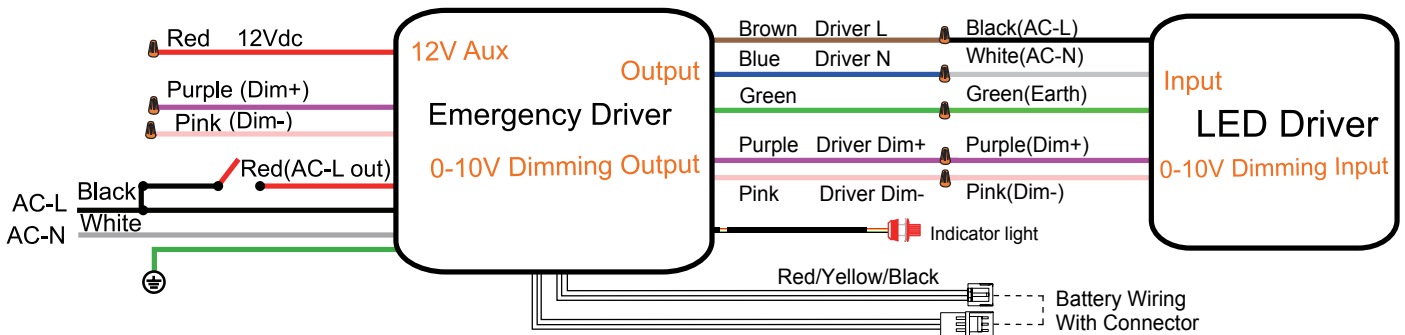

### IMPORTANT

Emergency driver 0-10V dimming wires must be connected to UFO LED driver dimming wires for EM to function properly. Will NOT operate if not connected.

### RECOMMENDATION

Emergency output power  $\geq 20\%$  output power of UFO LED Highbay

## Without Wall Switch & Dimmer, 24hr Lighting

For UFO LED Highbay <300W with 0-10V dimming function

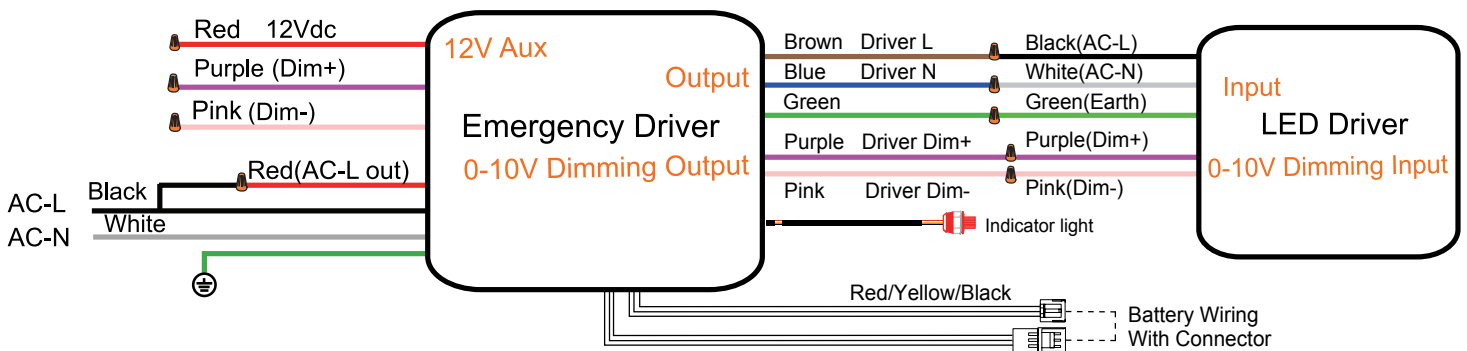

### IMPORTANT

Emergency driver 0-10V dimming wires must be connected to UFO LED driver dimming wires for EM to function properly. Will NOT operate if not connected.

### RECOMMENDATION

Emergency output power  $\geq 20\%$  output power of UFO LED Highbay



### With Sensor (100-277/347V AC)

For UFO LED Highbay <300W with 0-10V dimming function

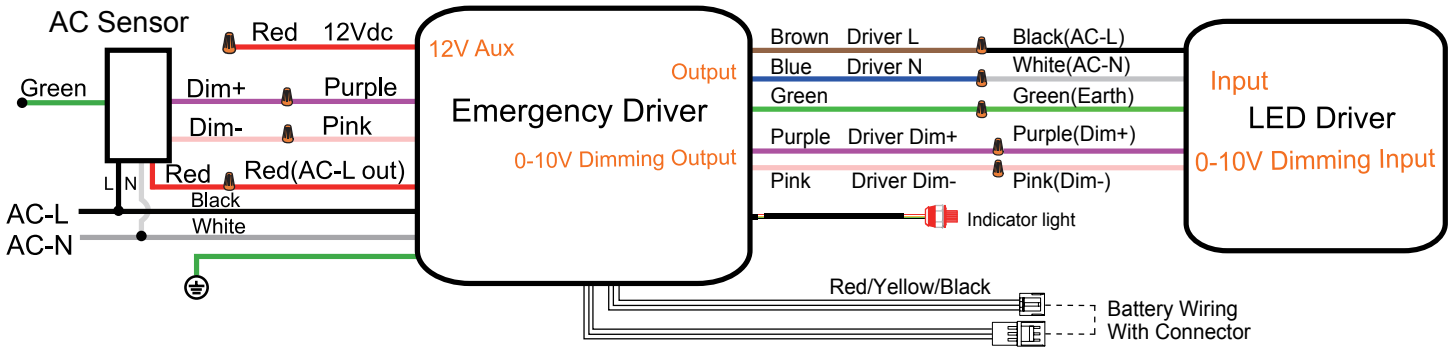

#### IMPORTANT

Emergency driver 0-10V dimming wires must be connected to UFO LED driver dimming wires for EM to function properly. Will NOT operate if not connected.

#### RECOMMENDATION

Emergency output power  $\geq 20\%$  output power of UFO LED Highbay

### With 12VDC Sensor

(The current is less than 30mA, and 12Vdc sensor must connect to emergency LED driver's 12Vdc wire, can't connect to UFO LED driver's 12Vdc wire. Please plug in the DC12V sensor before connecting to the mains.)

For UFO LED Highbay <300W with 0-10V dimming function

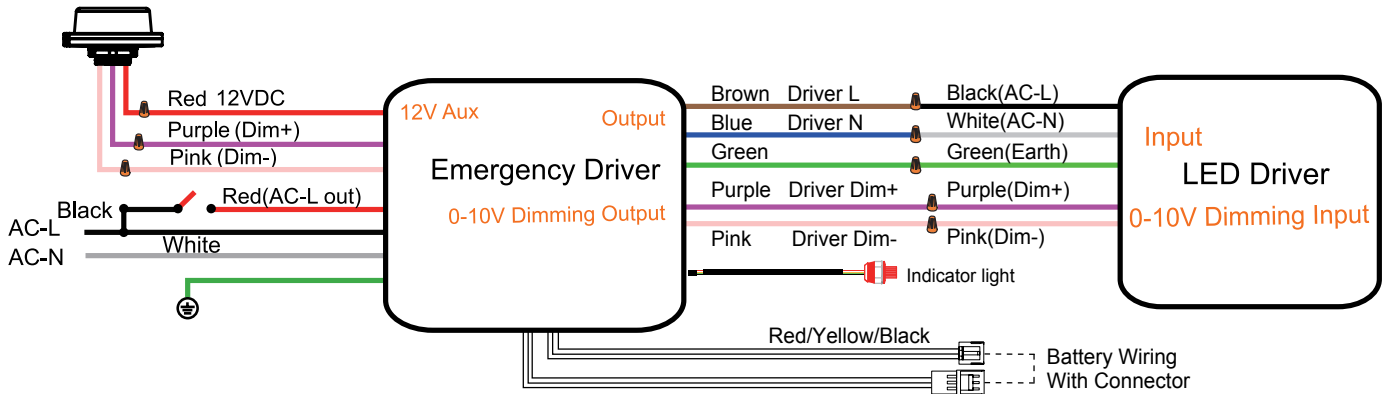

#### IMPORTANT

Emergency driver 0-10V dimming wires must be connected to UFO LED driver dimming wires for EM to function properly. Will NOT operate if not connected.

#### RECOMMENDATION

Emergency output power  $\geq 20\%$  output power of UFO LED Highbay

## Installation Instructions

### Step 1

Disconnect all power sources to the lighting fixture and ensure they are locked out during installation and maintenance. The LED driver must be sourced from the LED emergency driver. Select a suitable location on the ceiling with hangable device.

### Step 2

- (A) Install the ring bolt to the top thread hole of LED emergency driver and fix it with screw.
- (B1) Install the G-hook/Ring bolt/M10-rod/M12-rod to the Bottom thread hole of LED emergency driver and fix it with screw.
- (B2) Install the Rod to the Bottom thread hole of LED emergency driver and fix it with screw.
- (C) Install the LED emergency driver to UFO highbay fixture with screw. Open the LED emergency cover and remove the plastic covers and install the waterproof connectors

### Step 3

Pull all wires through the waterproof connectors into the Cavity of emergency driver.  
(A): Connect the AC output wires ( Brown,Blue and Green) of emergency driver with AC input wires of LED lighting fixture.



- (B): Connect the dimming output wires ( Purple and Pink) of emergency driver with the dimming input wires of LED Driver.
- (C): Connect AC input wires (Black,White and Red) of emergency driver with AC main power cord.
- (D): Connect the input dimming wires (Purple,Pink) of emergency driver with dimming wires from dimmer. Make sure all connections are with orange wiring caps in accordance with manufacture’s installation manual. Lock up the cover of junction box.
- (E): After all the wiring connections,and then connect the battery cable with quick connectors.

### Operation Instructions

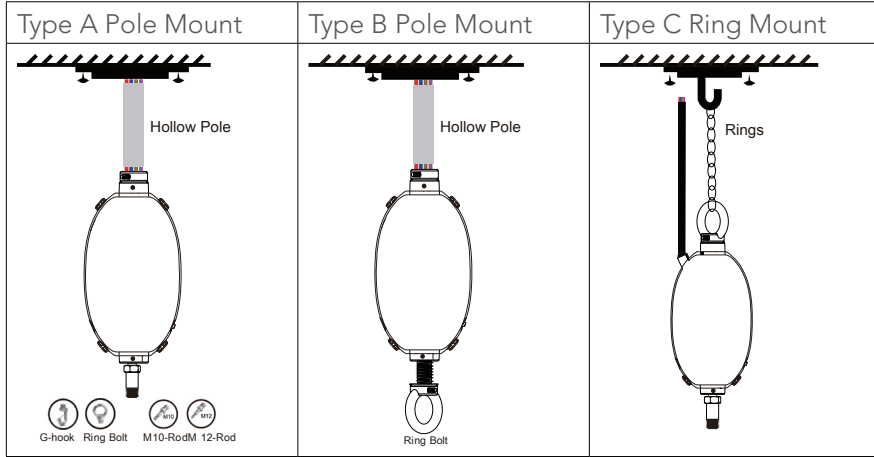

### Instructions for Remote Control (Standard)

Press the ON button to test emergenc function. This light will switch to its emergency lighting mode and the indicator will turn off

Press the OFF button, the light will revert to normal lighting mode.

When the main power supply is off (emergency mode), press the OFF button to turn off emergency function.

#### Test switch & indicator:

RED ON: Charging mode

RED OFF:Discharing mode

**Note:** The remote control must be pointed at the indicator light and be within a 45° angle to receive a signal/command. The remote control needs two AAA batteries to operate (not included).

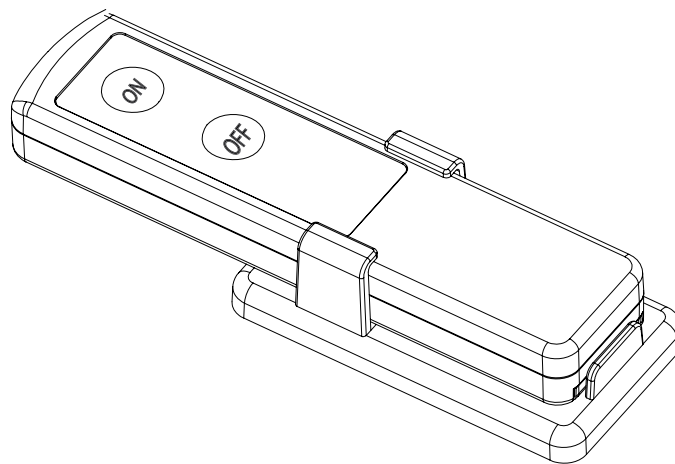



## IMPORTANT SAFEGUARDS

Follow all required local and national safety precautions including the following.

### READ AND FOLLOW ALL SAFETY INSTRUCTIONS.

- CAUTION: Do not join battery connector until installation is complete and ac power is supplied to the emergency inverter.
  - CAUTION: RISK OF SHOCK-disconnect emergency and normal input power sources before servicing.
  - ASSEMBLY and FIELD INSTALLATION WIRING: WARNING: AC power must be off, before proceeding with assembly or installation of emergency driver.
  - IMPORTANT: An unswitched AC power source is required (277-480 VAC, 50/60 Hz). This device is designed for fixtures listed for dry, damp or wet locations.
  - IMPORTANT: Please charge the battery consistently for >24 hours for the first time usage so as to activate the whole battery cells of discharging/charging duration.
  - IMPORTANT: Customers are advised to charge emergency LED drivers 24 hours every 6 months during storage, and which could be stocked for 1 year at most. If customers don't install and recharge for more than one year, the batteries may be damaged. This is not covered in the warranty, and we would charge for replacement.
  - IMPORTANT: Lighting fixture manufacturers, electricians, and end-users need to ensure product system compatibility test before using and final installation.
  - IMPORTANT: The LL-RH-EM30-HV is suggested to use for LED lamp less than 200W(when dimming to minimum, the power needs to be less than 25W). The LL-RH-EM40-HV is suggested to use for LED lamp less than 300W (when dimming to minimum, the power needs to be less than 35W).
  - IMPORTANT: Make sure all connections are in accordance with the National Electrical Code or Canadian Electrical Code and any local regulations.
  - CAUTION: To reduce the risk of electric shock disconnect both normal and emergency sources within this unit before servicing any equipment connected to this unit
  - CAUTION: Do not mount near gas or electric heaters.
  - CAUTION: Equipment should be mounted in locations and at heights where it will not be subjected to tampering by unauthorized personnel.
  - CAUTION: The use of accessory equipment not recommended by the manufacturer may cause an unsafe condition.
  - CAUTION: Do not use this equipment for other than its intended use.
  - CAUTION: Use with grounded, UL Listed, dry or damp location rated fixtures. Case should also be grounded.
  - CAUTION: This product is for use in indoor fixtures only. Do NOT use near heated air handling outlets or hazardous locations. Suitable for use in 5°C -50°C ambient temperatures. Max. mounting height: 48.65ft.
  - CAUTION: Battery is rechargeable Li-ion type and must be recycled or disposed of properly
- Do not use this emergency driver with accessory equipment other than recommended by the manufacturer. . Failure to follow this may cause an unsafe condition and will void warranty. Servicing of this equipment should be performed by qualified personnel only.
- IMPORTANT: Illuminated Indicator (LED light) means battery is in charge mode when AC power is applied. It is recommended and required by applicable code to test emergency function to ensure proper operation of the system; press the remote controller ON button every 30 days to ensure the emergency driver is functioning and LED light source is illuminated. Conduct a ninety minute (90) discharge test one time (1) per year; LED light source should be illuminated for a minimum of ninety minutes (90).
  - TESTING SYSTEM: The emergency battery requires a minimum charge of one (1) hour before testing the circuit. A full charge requires twenty four(24) hours.



<b>Project Name</b>	
<b>Catalog #</b>	
<b>Job Type</b>	
<b>Prepared By</b>	
<b>Notes</b>	

## Ordering Information

<b>Part #</b>	<b>Description</b>
LL-RH-EM30-HV-R	Round Highbay Emergency Battery Back Up 30W 277-480V With Remote Control
LL-RH-EM40-HV-R	Round Highbay Emergency Battery Back Up 40W 277-480V With Remote Control
LL-RH-EM60-HV-R	Round Highbay Emergency Battery Back Up 60W 277-480V With Remote Control